

# Seasonal Forecast: performance and developments

*Laura Ferranti, Magdalena Balmaseda,  
Franco Molteni, Kristian Mogensen,  
Tim Stockdale, Frederic Vitart, Thomas Jung*

## Outline:

### **ECMWF Seasonal Forecast System and EUROSIP multi-model system:**

- Description and EUROSIP updates

### **Past performance:**

- Predictions of El Niño 2009 and its effect over the tropical and extra-tropical regions

### **Verification:**

- Use a moving climatology to better estimate the seasonal forecast skill in capturing the year to year variations

### **Future developments:**

- System 4

# ECMWF Seasonal forecast system (Sys-3)



## Initial Conditions

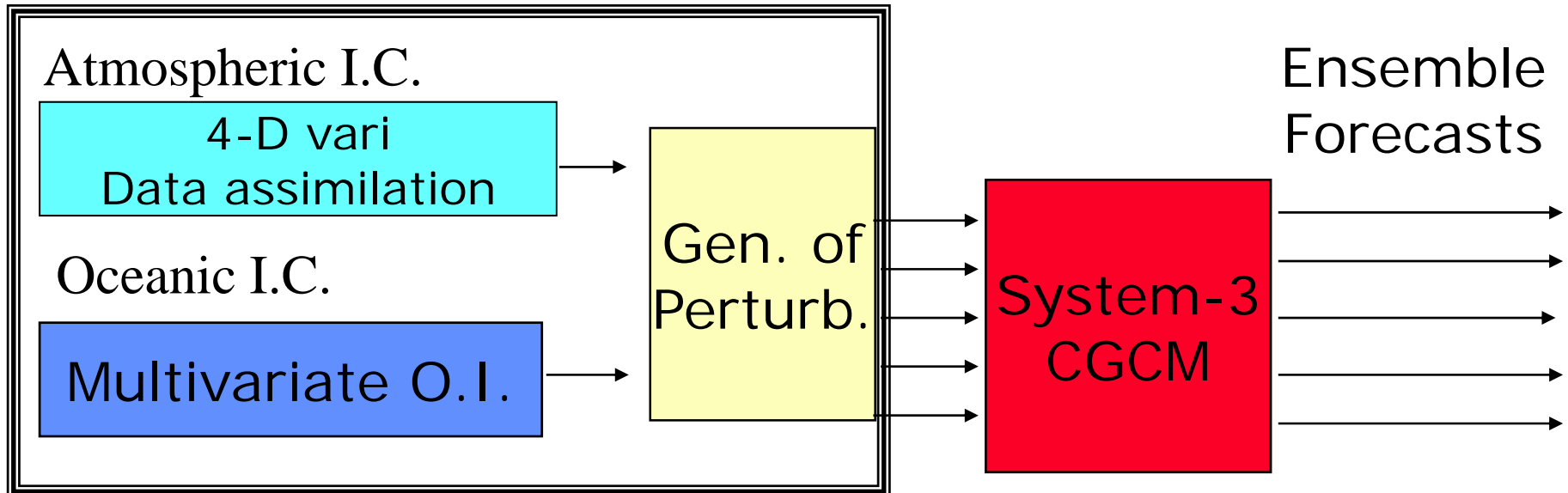

# Nino3.4 annual predictions:

NINO3.4 SST anomaly plume  
ECMWF forecast from 1 Nov 2008

Monthly mean anomalies relative to NCEP adjusted OIv2 1971-2000 climatology

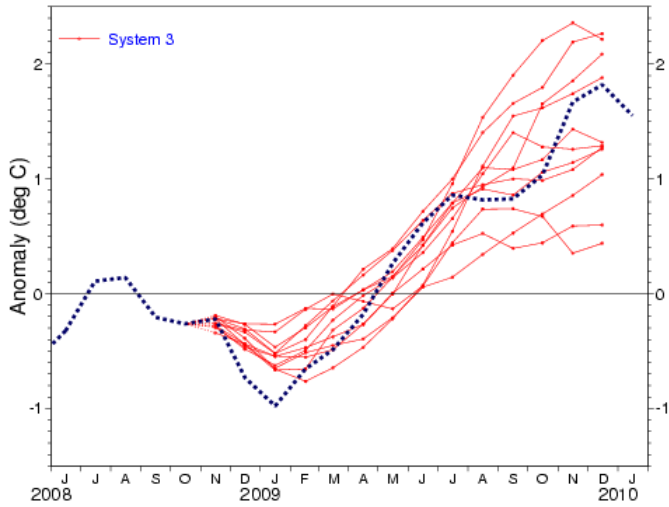

NINO3.4 SST anomaly plume  
ECMWF forecast from 1 May 2009

Monthly mean anomalies relative to NCEP adjusted OIv2 1971-2000 climatology

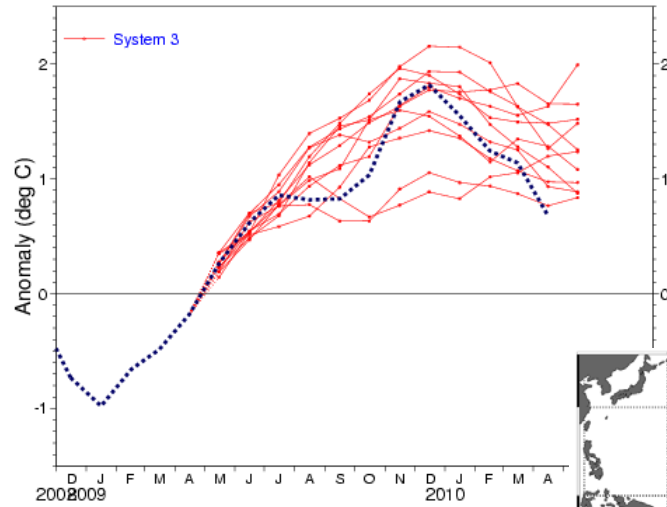

NINO3.4 SST anomaly plume  
ECMWF forecast from 1 Feb 2009

Monthly mean anomalies relative to NCEP adjusted OIv2 1971-2000 climatology

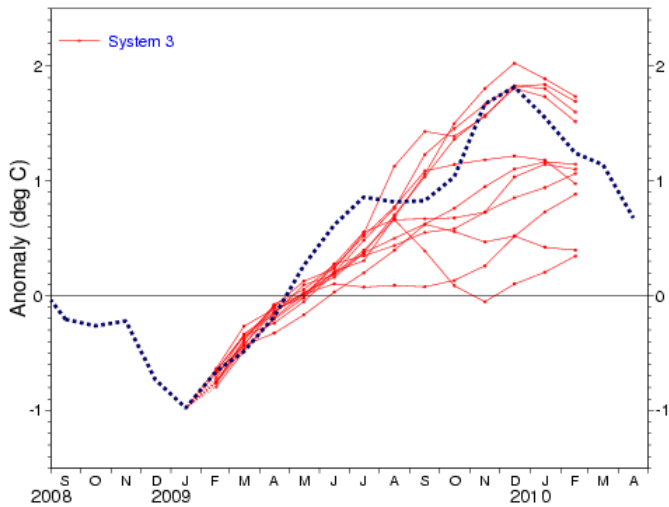

NINO3.4 SST anomaly plume  
ECMWF forecast from 1 Nov 2009

Monthly mean anomalies relative to NCEP adjusted OIv2 1971-2000 climatology

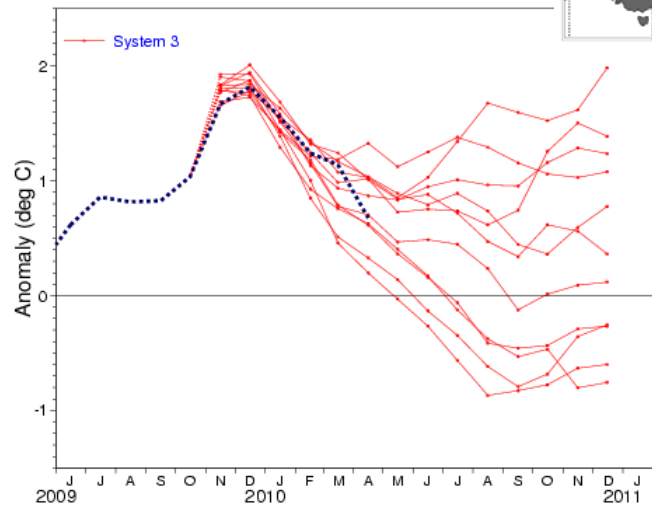

Nino3.4 area

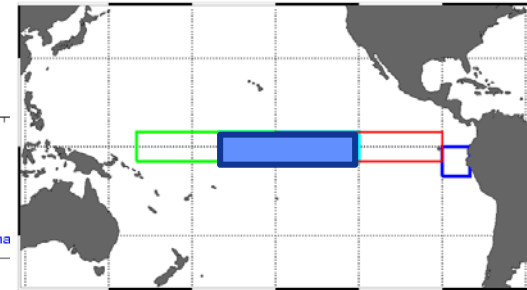

# EUROSIP multi-model system:

## 3 Coupled Systems:

ECMWF, Météo France, Met Office

Hind-cast period: 1981-2005 for Ecmwf/Météo France and 1989-2002 for Met Office.

Development of multi-model products is ongoing and the EUROSIP products are available to all Member States and WMO users.

Digital multi-model products are available since September 2008.

# Nino3.4 seasonal predictions:

## ECMWF

NINO3.4 SST anomaly plume

ECMWF forecast from 1 May 2009

Monthly mean anomalies relative to NCEP adjusted OIv2 1971-2000 climatology

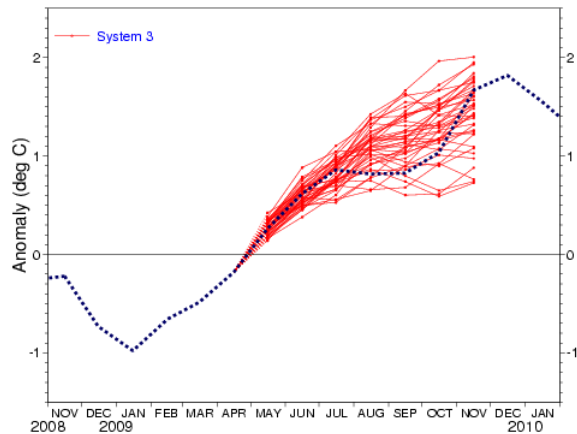

NINO3.4 SST anomaly plume

ECMWF forecast from 1 Aug 2009

Monthly mean anomalies relative to NCEP adjusted OIv2 1971-2000 climatology

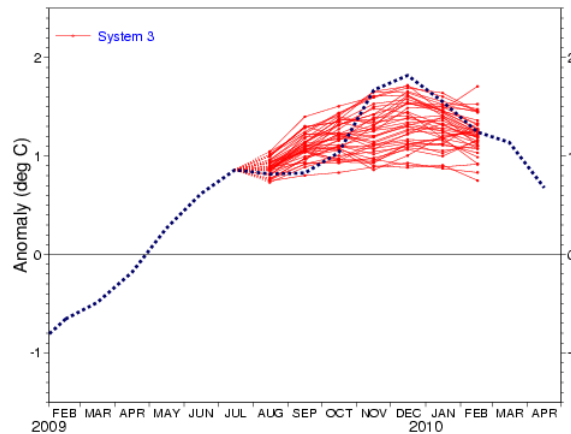

NINO3.4 SST anomaly plume

ECMWF forecast from 1 Nov 2009

Monthly mean anomalies relative to NCEP adjusted OIv2 1971-2000 climatology

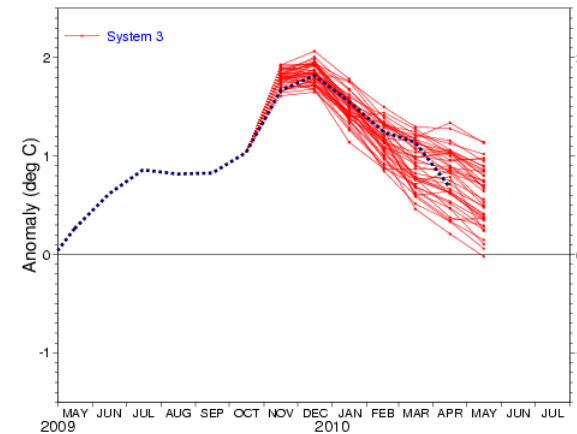

## EUROSIP

NINO3.4 SST anomaly plume

EUROSIP multi-model forecast from 1 May 2009

ECMWF, Met Office, Météo-France

Monthly mean anomalies relative to NCEP adjusted OIv2 1971-2000 climatology

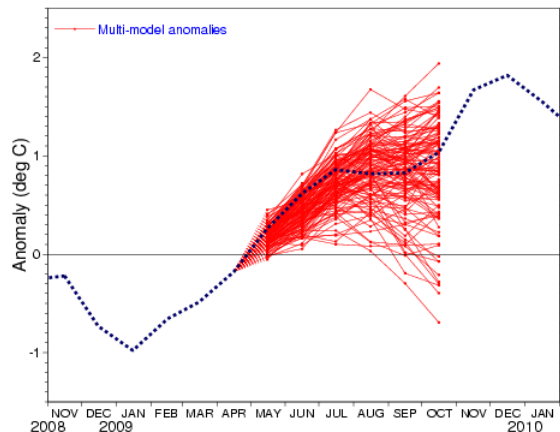

NINO3.4 SST anomaly plume

EUROSIP multi-model forecast from 1 Aug 2009

ECMWF, Met Office, Météo-France

Monthly mean anomalies relative to NCEP adjusted OIv2 1971-2000 climatology

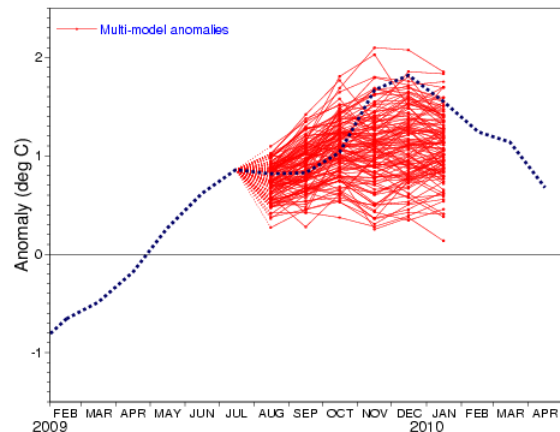

NINO3.4 SST anomaly plume

EUROSIP multi-model forecast from 1 Nov 2009

ECMWF, Met Office, Météo-France

Monthly mean anomalies relative to NCEP adjusted OIv2 1971-2000 climatology

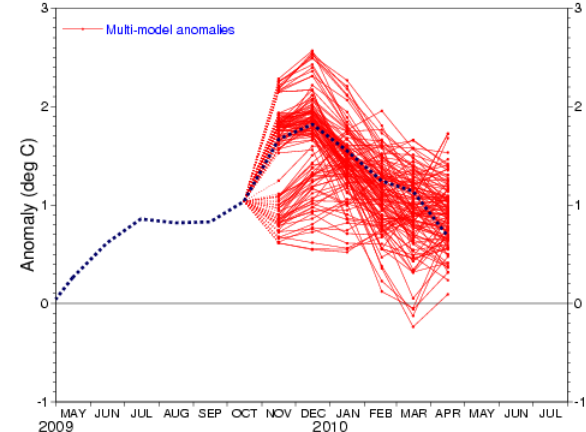

## EUROSIP multi-model system:

The composition of the multi-model ensemble changes when one of the component is upgraded.

**Latest model change: September 2009**

**Met Office new system GloSea4 was introduced.**

- enhanced resolution
- different ocean model
- ensemble is generated using lagged i.c.
- hind-cast is limited to 1989-2002
- runs in Exeter, only a limited number of fields are transmitted.

**From September 2009 the EUROSIP tropical storm forecasts is based on data from ECMWF and Météo France systems.**

ROC 2m temp  
upper tercile  
August starts  
(1989-2002)  
months 2-4

Eurosip/Glosea4

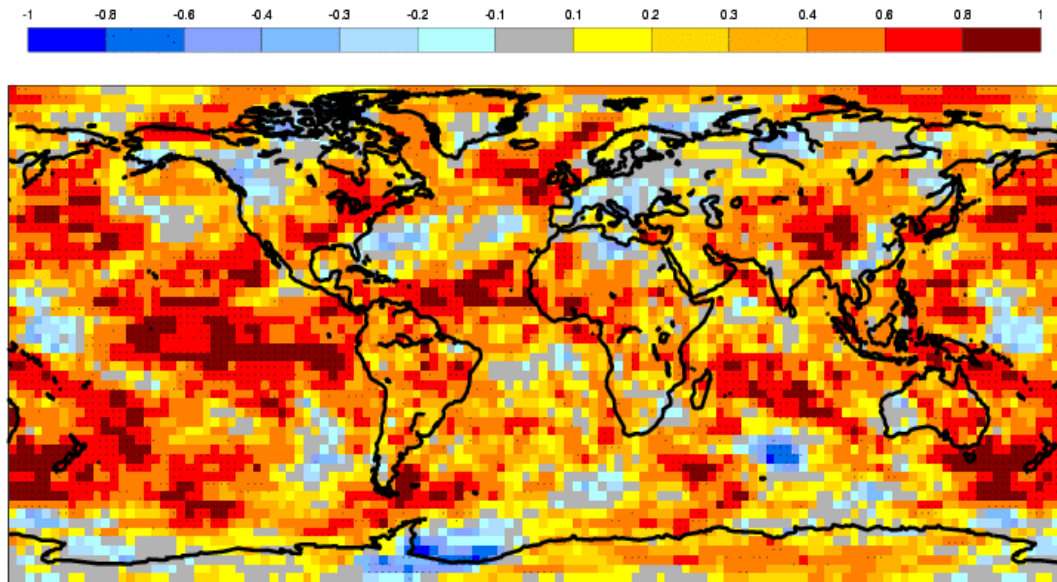

Eurosip/Glosea3

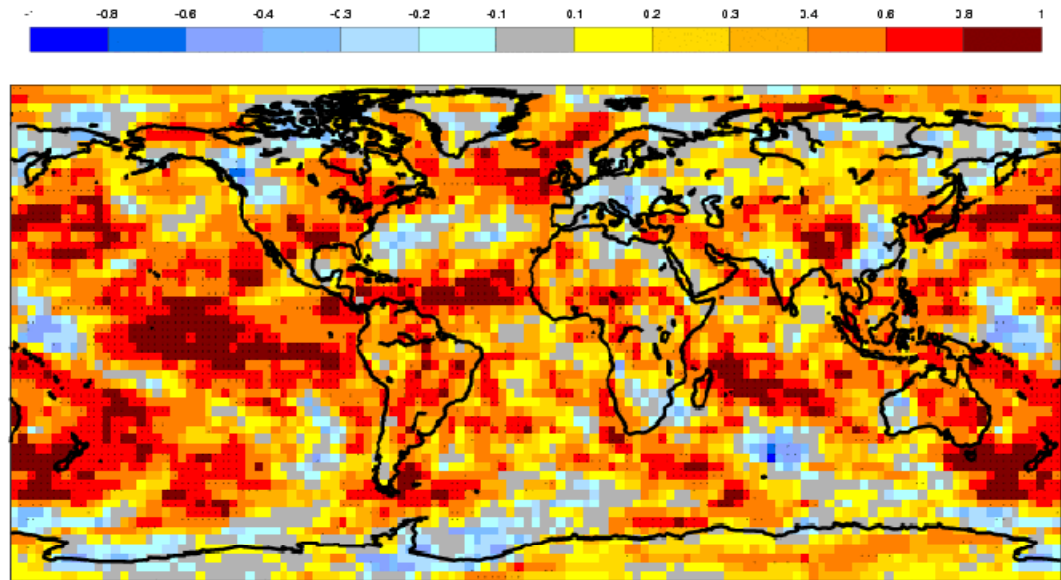

# ECMWF Seasonal Forecast Tropical Storm Frequency

Forecast start reference is 01/06/2009  
Ensemble size = 41, climate size = 176

System 3  
JASOND 2009  
Climate = 1990-2005

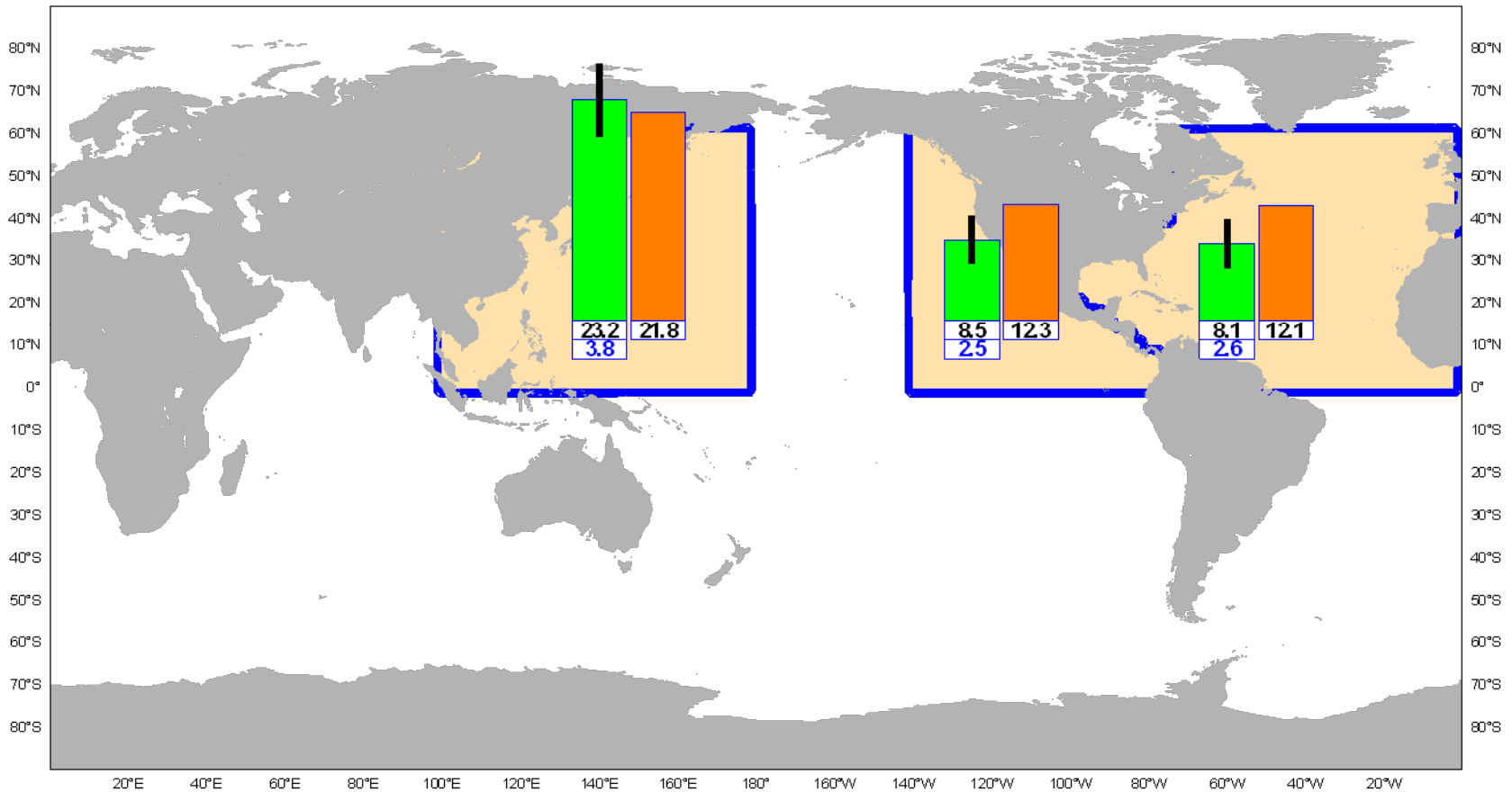

Not Significant

Significant at 5%

# Verification of 2009 Atlantic Hurricane Season

	TS	ACE
<b>Forecast</b>	<b>8 +/-2.6</b>	<b>40 (+/-20)</b>
<b>OBS</b>	<b>9</b>	<b>52</b>
<b>CLIM</b>	<b>12.1</b>	<b>100</b>
<b>Corr. 1990-2009</b>	<b>0.56</b>	<b>0.77</b>



Centre	Date of issue	Tropical storms	ACE index
CSU	10 <sup>th</sup> December 2008	14	125
	7 <sup>th</sup> April 2009	12	100
	2 <sup>nd</sup> June 2009	11	85
	4 <sup>th</sup> August 2009	10	80
TSR	5 <sup>th</sup> December 2008	14.8 (±4.3)	136 (±60)
	6 <sup>th</sup> April 2009	15 (±3.8)	135 (±56)
	4 <sup>th</sup> June 2009	<b>10.9 (±3.3)</b>	<b>69 (±50)</b>
	6 <sup>th</sup> July 2009	11.4 (±3.2)	80 (±46)
	4 <sup>th</sup> August 2009	12.6 (±2.8)	105 (±40)
NOAA*	21 <sup>st</sup> May 2009	9–14	57–114
	6 <sup>th</sup> August 2009	7–11	52–96
Met Office	18 <sup>th</sup> June 2009	<b>6 (3–9)</b>	<b>60 (40–80)</b>
ECMWF	June 2009	8.1 (±2.6)	40 (±20)
EUROSIP	June 2009	6.3 (±2.8)	--

**Table 5.** Seasonal forecasts of 2009 North Atlantic tropical storm activity from Colorado State University (CSU), Tropical Storm Risk (TSR), National Oceanic and Atmospheric Administration (NOAA), the Met Office, the European Centre for Medium Range Weather Forecasts (ECMWF), and the EUROSIP multi-model system. The Met Office and EUROSIP seasonal forecasts are for the period July–November only, the ECMWF forecast is for the July to December period. ECMWF and EUROSIP forecasts are available through the Met Office and other ECMWF member states. \*Values quoted for NOAA are based on predicted percentages of the 1951–2000 median of 87.5. Forecasts are highlighted in bold where the observed activity was within the predicted range.

# Atlantic Hurricane Season Nov 2008 Forecast

## ECMWF Seasonal Forecast Tropical Storm Frequency

Forecast start reference is 01/11/2008  
Ensemble size = 11, climate size = 60

System 3  
JJASOND 2009  
Climate = 1990-2005

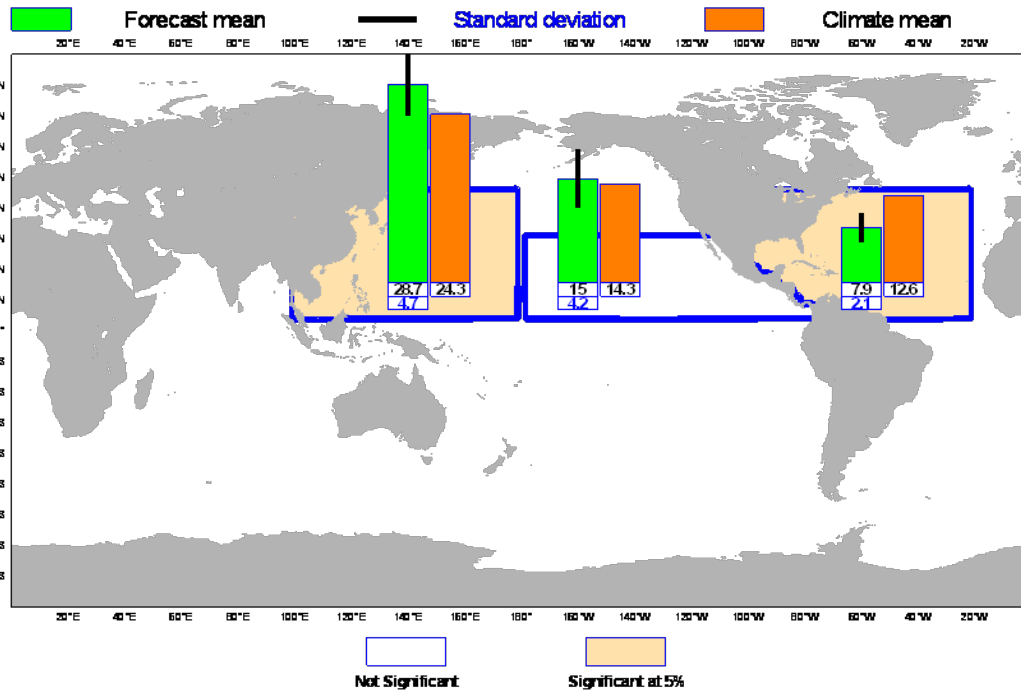

## NINO3 SST anomaly plume ECMMF forecast from 1 Nov 2008

Monthly mean anomalies relative to NCEP adjusted OIv2 1971-2000 climatology

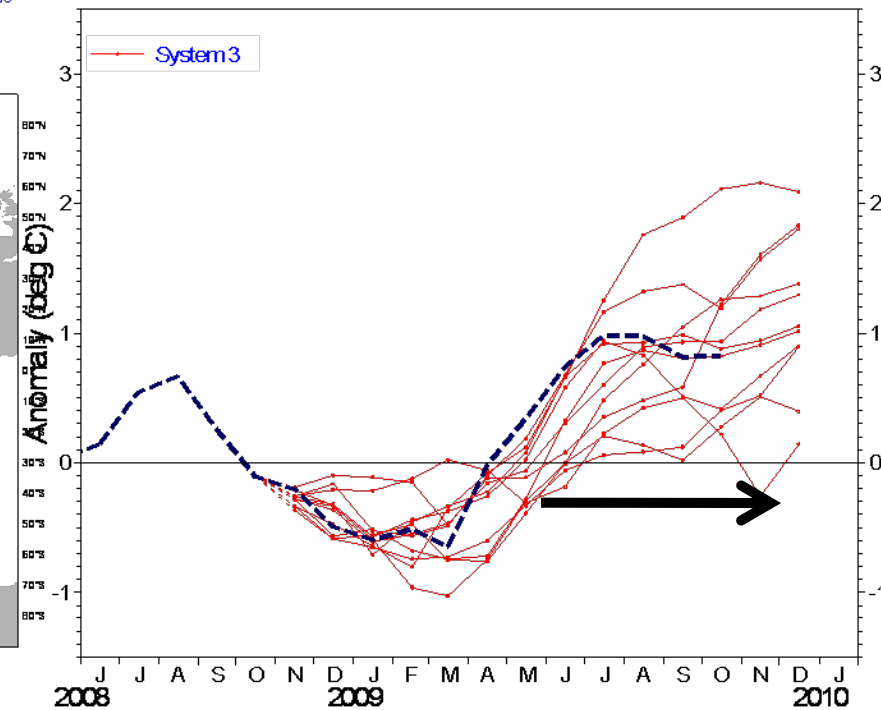

Forecast issue date: 15 Nov 2008

# ECMWF Seasonal Forecast North Atlantic Accumulated Cyclone Energy

System 3  
JASOND

Forecast start reference is 01/06/YYYY  
Calibration period = 1990-2005  
Ensemble size = 11 (real time = 41)

Correlation= 0.73 ( 1.00)  
RMS Error= 0.39 ( 0.58)

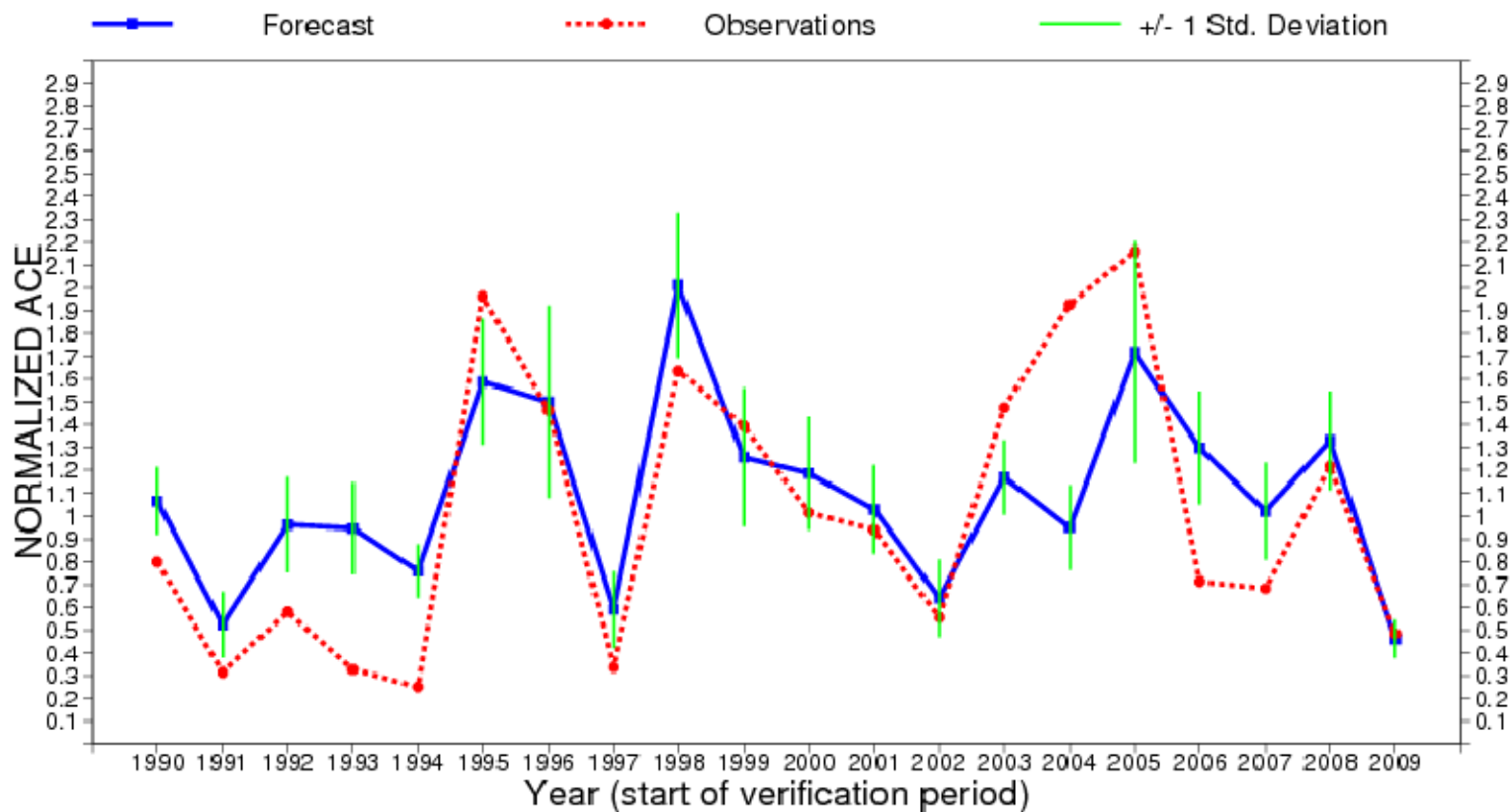

ECMWF Seasonal Forecast System 3  
 Mean 2m temperature anomaly DJF 2009/10

Forecast start reference is 01/11/09  
 Ensemble size = 41, climate size = 275  
 Shaded areas significant at 10% level  
 Solid contour at 1% level

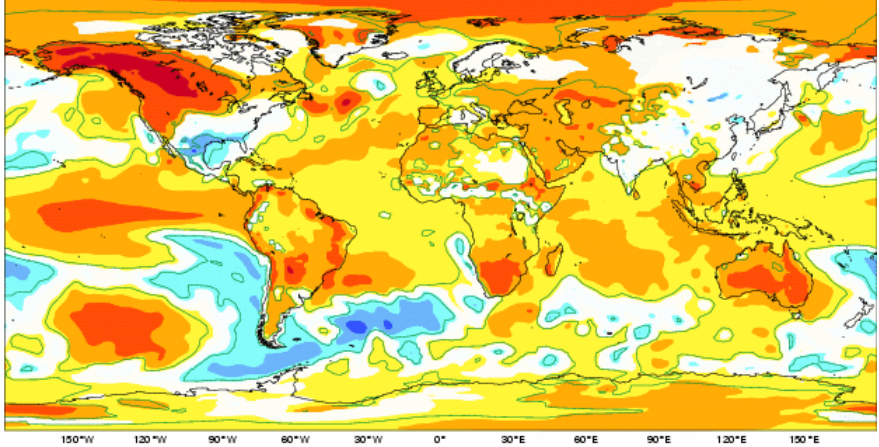

Latest issue date: 15/11/2009

EUROSIP multi-model seasonal forecast Mean 2m temperature anomaly DJF 2009/10

Forecast start reference is 01/11/09  
 Variance-standardized mean  
 No significance test applied

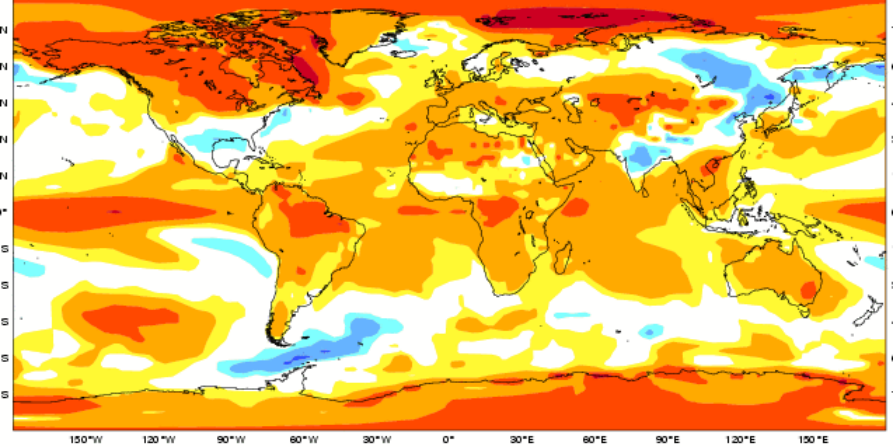
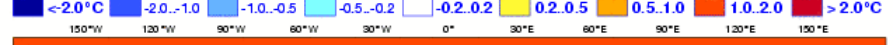

Latest issue date: 15/11/2009

# DJF 2009/10

ECMWF analysis Mean 2m temperature anomaly DJF 2009/10

Ensemble size = 1, climate size = 25  
 Legend: <-2.0°C (dark blue), -2.0..-1.0 (blue), -1.0..-0.5 (light blue), -0.5..-0.2 (cyan), -0.2..0.2 (white), 0.2..0.5 (yellow), 0.5..1.0 (orange), 1.0..2.0 (red), >2.0°C (dark red)

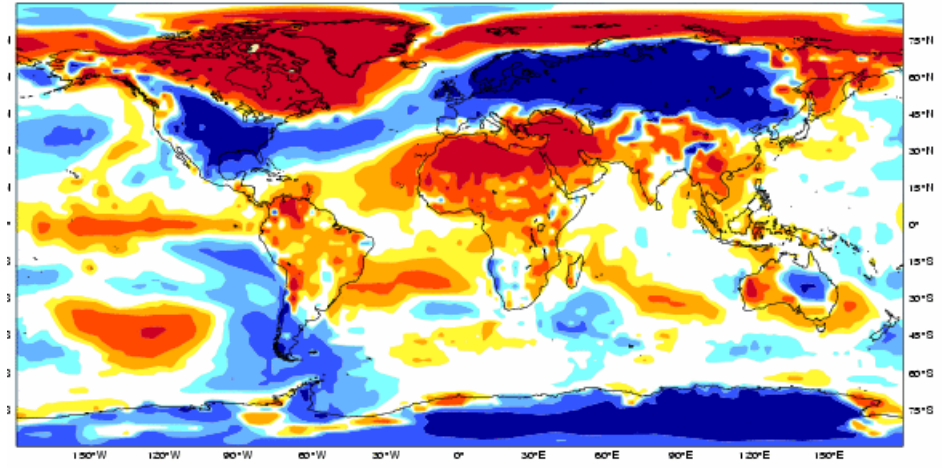

# NAO Forecast and verification:

## Ecmwf Nov. 2009

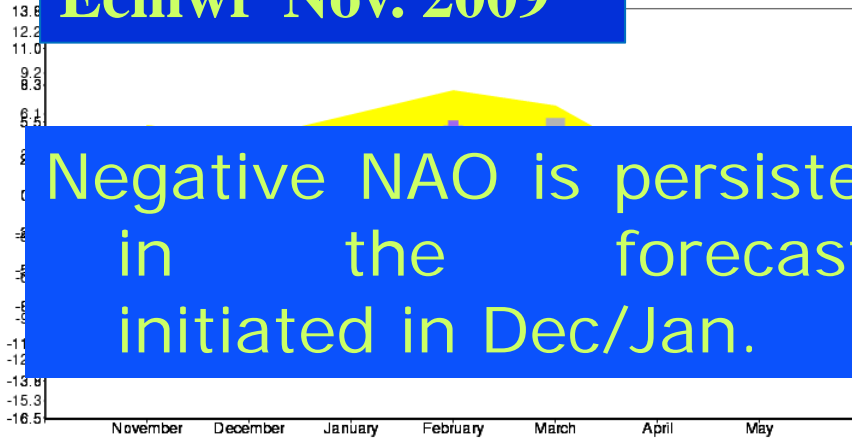

eof 1: North Atlantic Oscillation (NAO)

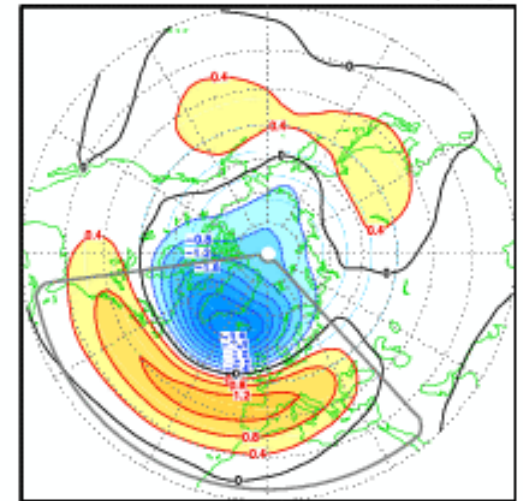

## Ecmwf Dec. 2009

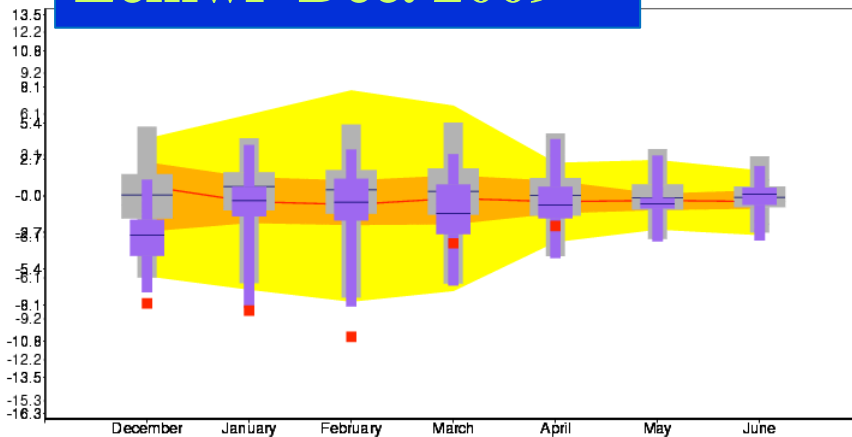

## Ecmwf Jan. 2010

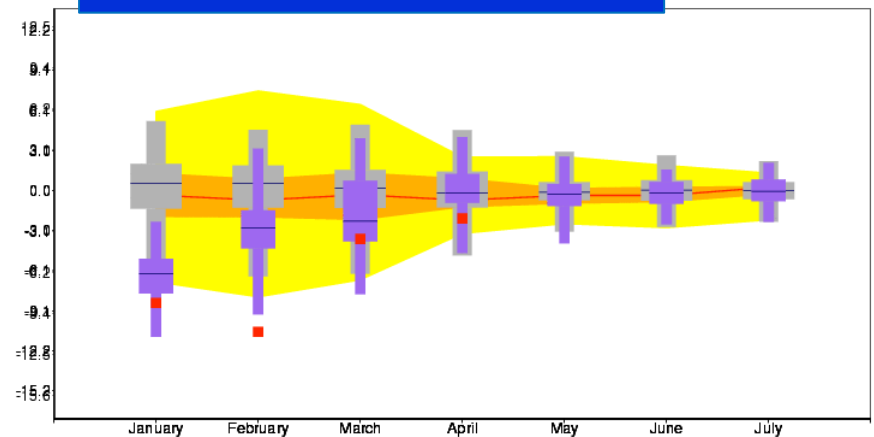

# DJF 2009/10

## ECMWF Seasonal Forecast Mean 2m temperature anomaly

Forecast start reference is 01/11/09  
Ensemble size = 41, climate size = 275

System 3  
DJF 2009/10  
Shaded areas significant at 10% level  
Solid contour at 1% level

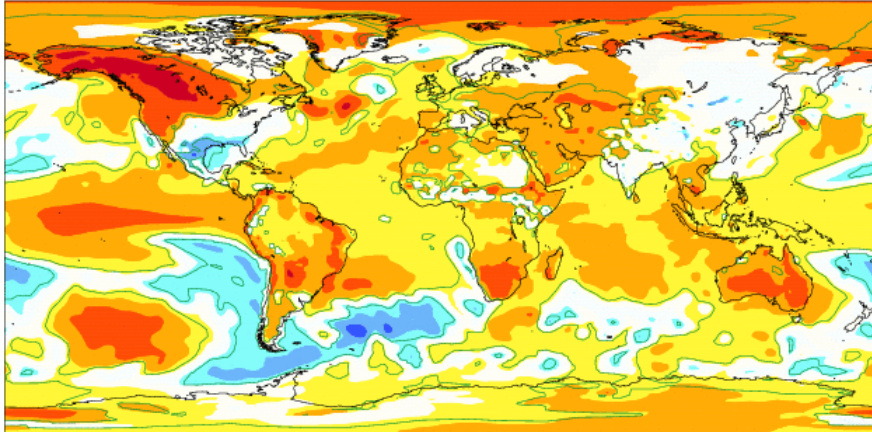

## ECMWF analysis Mean 2m temperature anomaly

DJF 2009/10

Ensemble size = 1, climate size = 25

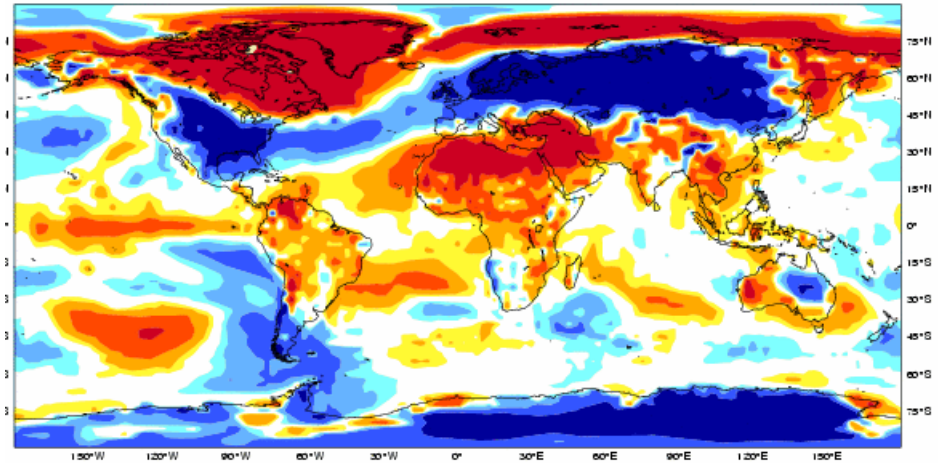

## EUROSIP multi-model seasonal forecast Mean 2m temperature anomaly

Forecast start reference is 01/11/09  
Variance-standardized mean

ECMWF/Met Office/Météo-France  
DJF 2009/10  
No significance test applied

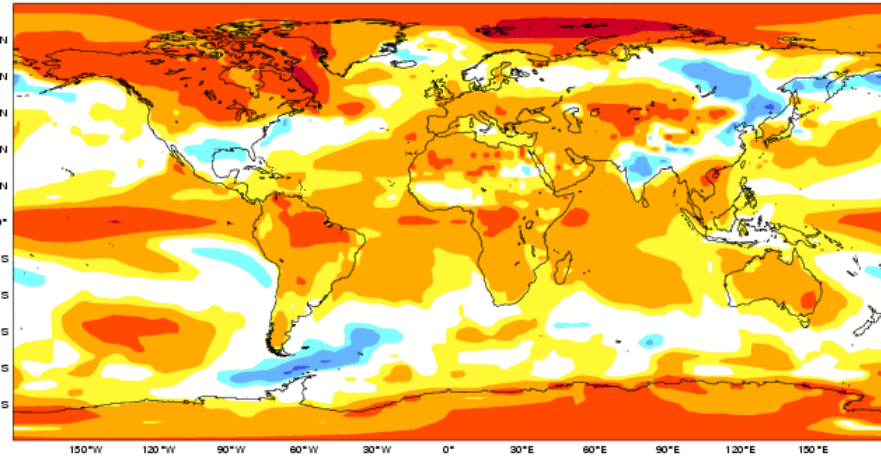
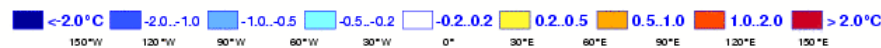

## Observed SST diagnostic run Mean 2m temperature anomaly

Forecast start reference is 01/11/09  
Ensemble size = 41, climate size = 275

System 3  
DJF 2009/10  
Shaded areas significant at 10% level  
Solid contour at 1% level

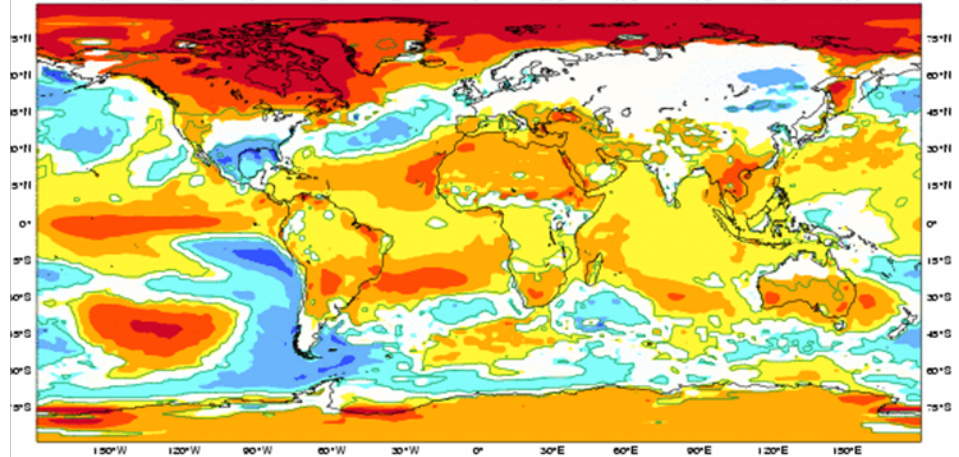

# Conclusion

The ENSO event that picked in December 2009 was well predicted since November 2008.

So far results from the EUROSIP verification indicate that GLOSEA4 contributes to the skill of the multi model system to the same extent than GLOSEA3 did.

Good forecasts for the Atlantic and Western Pacific tropical storm seasons 2009.

## Conclusion: DJF 2009/10 performance

- Over the Pacific sector the anomalies associated with ENSO response were reproduced.
- Over the Atlantic sector the large and persisted anomalies associated with the Negative NAO pattern were not well predicted.

Sensitivity experiments indicate:

- slightly better forecasts when the ECMWF model is forced by observed SSTs, or when the Tropics are relaxed towards observations.
- No significant impact when the stratosphere is relaxed towards observations.
- the amplitude of the anomalies are never well capture, so far no clear source of predictability for this very unusual winter has been found.

# Verification with a moving climate to deal with long-term trends:

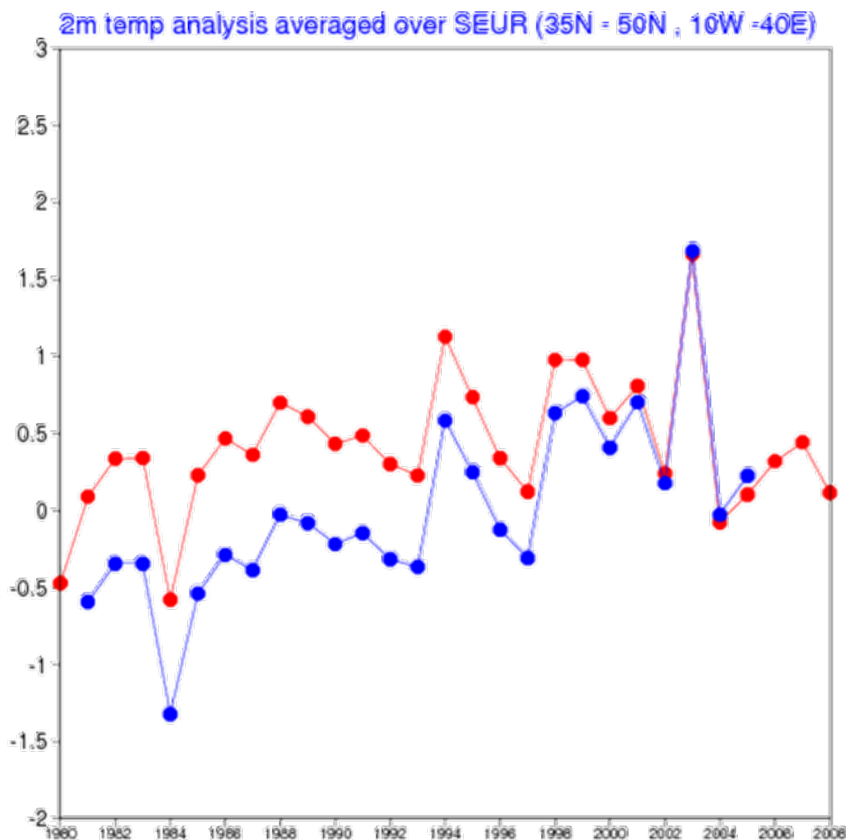

anomalies with respect to a fixed climate (1981-2005)

anomalies with respect to a moving climate :  
(1960-1979, 1961-1980.....  
..... 1988-2007)

Southern Europe 2-metre temperature  
 ORecmfEX0001SY03M1 with 11 ensemble members  
 Hindcast period 1981-2005  
 Start date May and fcst. time 2 to 4

Ratio of sd (model/ref): 1.00  
 Ratio spread/RMSE: 0.74  
 Ens. mean correlation: 0.68 (0.00)  
 SNR: 0.92 (0.68)  
 RPSS: 0.39 (0.00)  
 RPSSd: 0.44 (0.00)

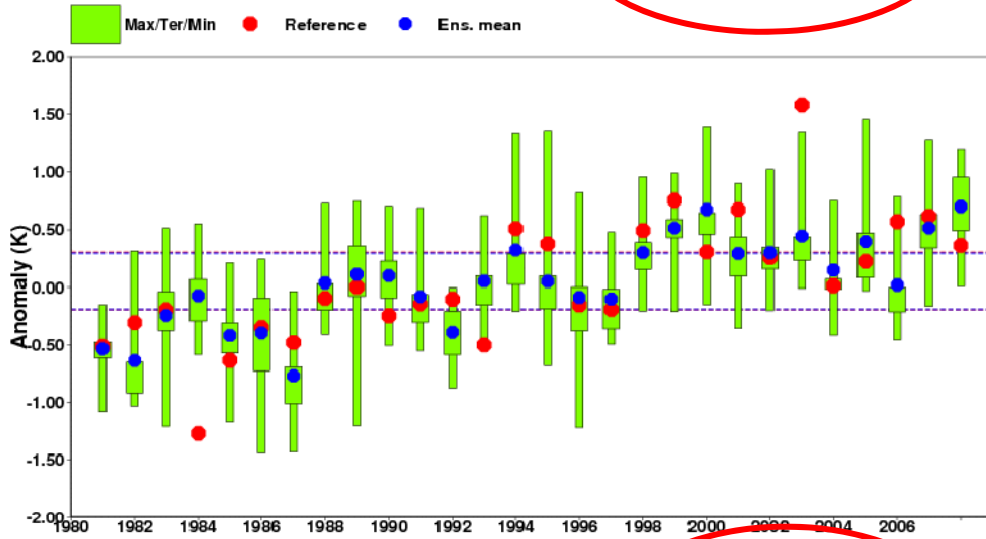

Fixed climate

Southern Europe 2-metre temperature  
 ORecmfEX0001SY03M1 with 11 ensemble members  
 Hindcast period 1960-1979  
 Start date May and fcst. time 2 to 4

Ratio of sd (model/ref): 1.18  
 Ratio spread/RMSE: 0.74  
 Ens. mean correlation: 0.36 (0.06)  
 SNR: 0.62 (1.00)  
 RPSS: 0.14 (0.00)  
 RPSSd: 0.21 (0.00)

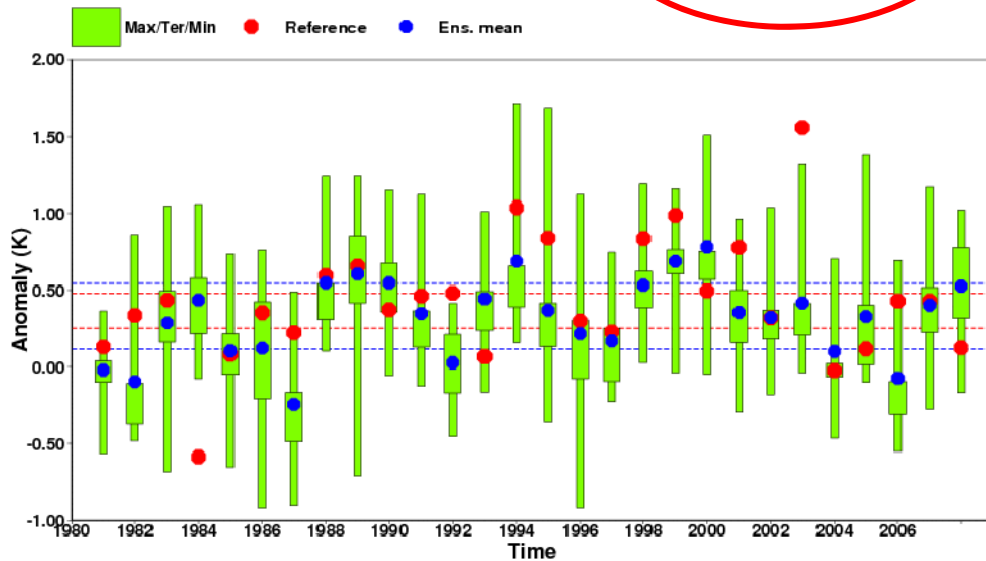

Moving climate

Anomaly Correlation Coefficient for ECMWF with 11 ensemble members  
Near-surface temperature  
Hindcast period 1981-2005 with start in May average over months 2 to 4  
Black dots for values significantly different from zero with 95% confidence ( 1000 samples)

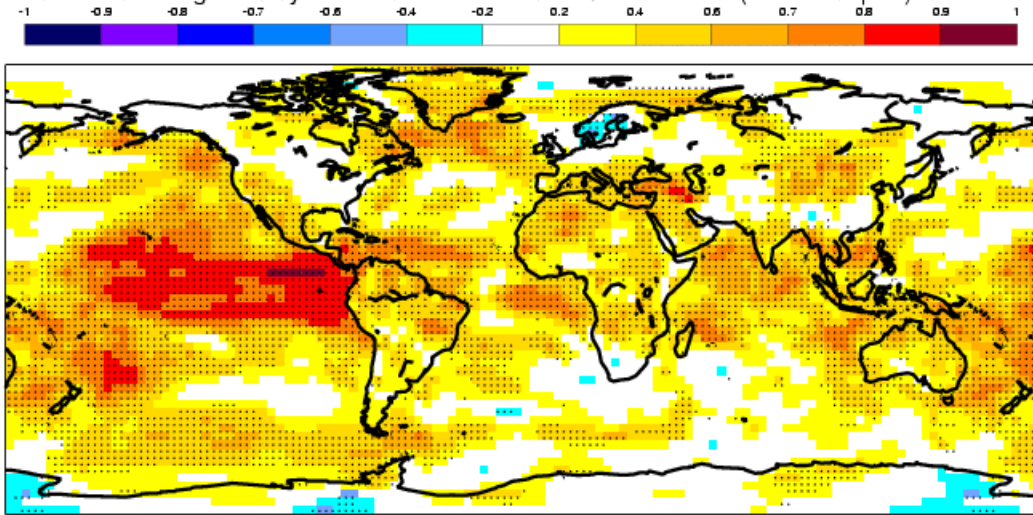

Fixed climate

Anomaly Correlation Coefficient for Eurosip with 11 ensemble members  
Near-surface air temperature  
Hindcast period 1960-1979 with start in May average over months 2 to 4  
Black dots for values significantly different from zero with 95% confidence ( 1000 samples)

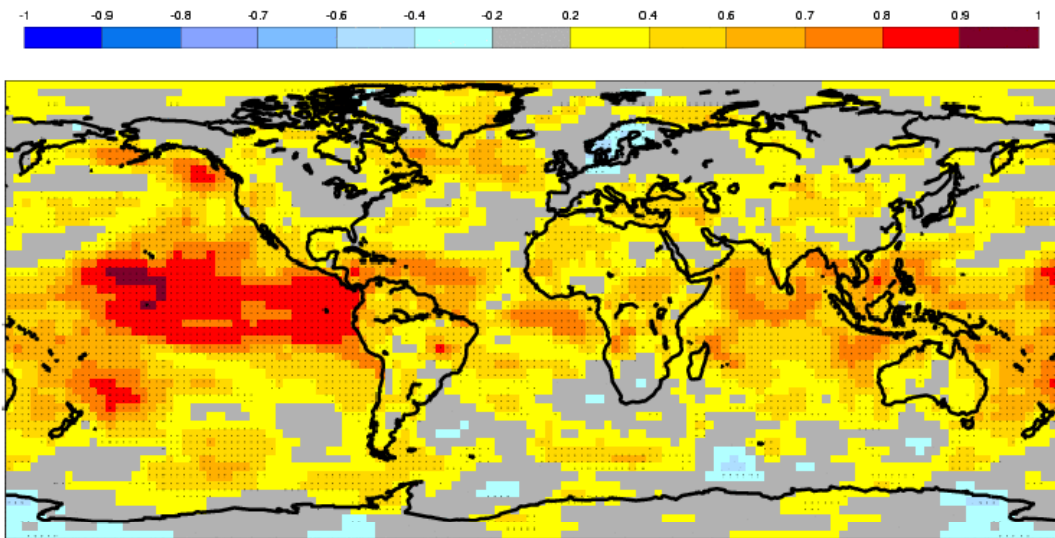

Moving climate

# Latest ENSO predictions:

The latest forecasts show a high probability of negative anomalies in Central Pacific by the end of Summer 2010, consistent with that enhanced hurricane activity is predicted.

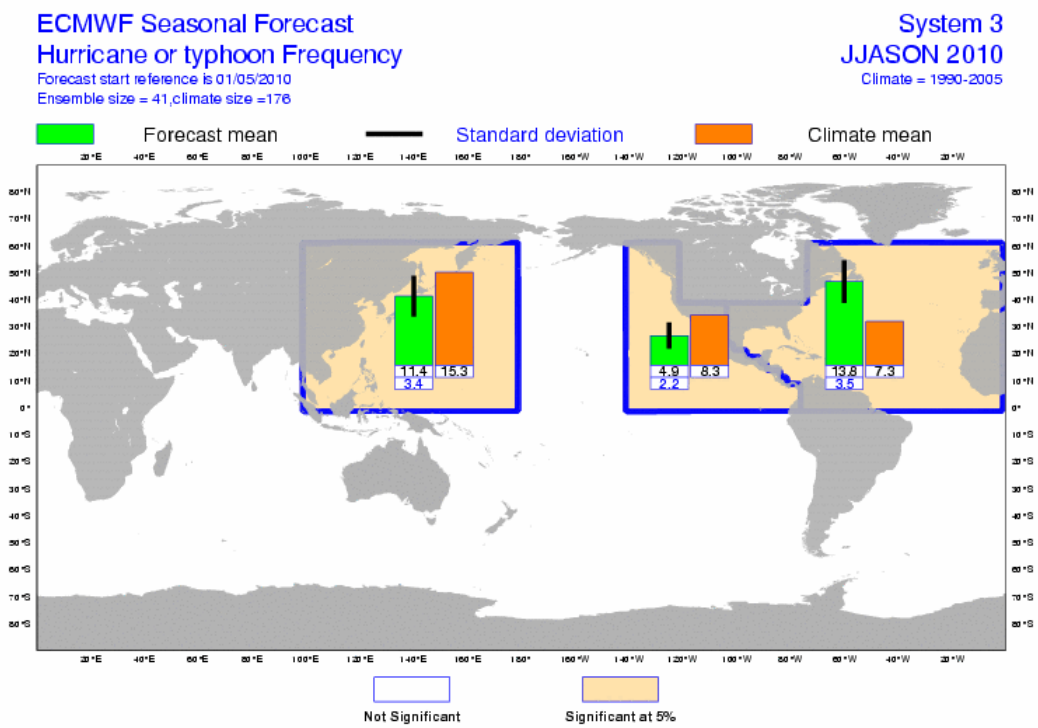
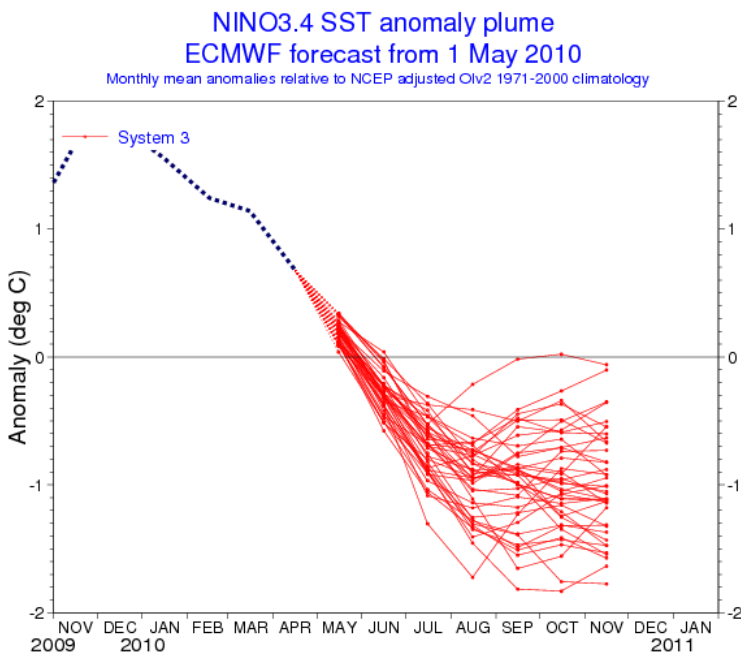

## Future implementations:

- **The seasonal forecasting group is testing a new seasonal forecast system: System 4**
- An ocean (re-)analysis system using a completely new ocean model and data assimilation system has been set up.
- Work to define the final configuration is in progress.
- Operational implementation is expected by late 2010 or early 2011.

# System 4: main features

- **New ocean model : NEMO v. 3.0 + 3.1 coupling interface**
  - **ORCA-1 configuration (~1-deg. resol., ~0.3 lat. equatorial refinement)**
  - **42 vertical levels, 20 levels with  $z < 300$  m**
- **Variational ocean data assimilation (NEMOVAR)**
  - **3-D var with inner and outer loop**
  - **Collaboration with CERFACS, UK Met Office, INRIA**
  - **First re-analysis (1957-2009), assimilating T/S completed.**
  - **Second re-analysis and real-time system including SLA**
- **IFS model cycle: most likely 36r4 (36r1 currently operational)**
  - **New physics package, including HTESSEL land-surface scheme, snow model (with EC-Earth), new land surface initialization**
- **New formulation for prescribed sea-ice concentration**
  - **Sampling from most recent years**

## Future implementations:

- **The seasonal forecasting group is testing a new seasonal forecast system: System 4**
- **An ocean (re-)analysis system using a completely new ocean model and data assimilation system has been set up.**
- **Work to define the final configuration is in progress.**
- **Operational implementation is expected by late 2010 or early 2011.**

# An outstanding modelling issue: tropical wind biases

Streamfunction 850hPa er40 (12-2 1963-2006)

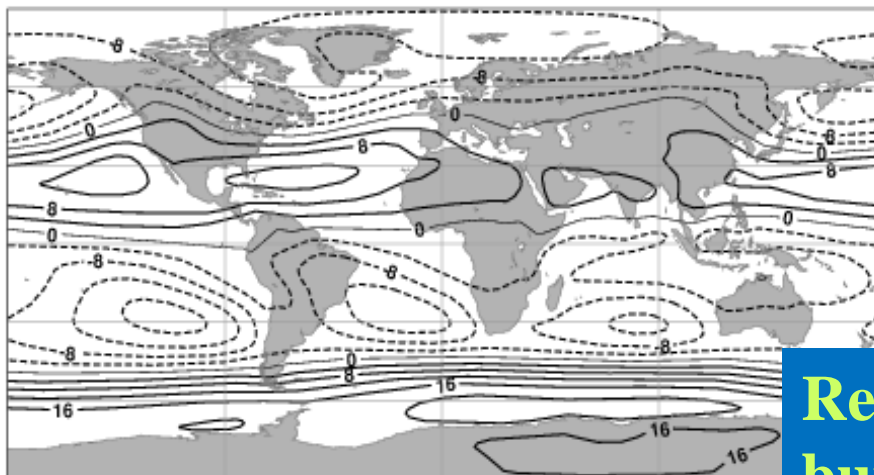

**Biases in 850 hPa  
streamfunction  
(obs SST, DJF 1963-2006)**

**Reduced biases at mid-latitudes  
but too strong trades winds**

Streamfunction 850hPa 31R1-er40 (12-2 1963-2006)

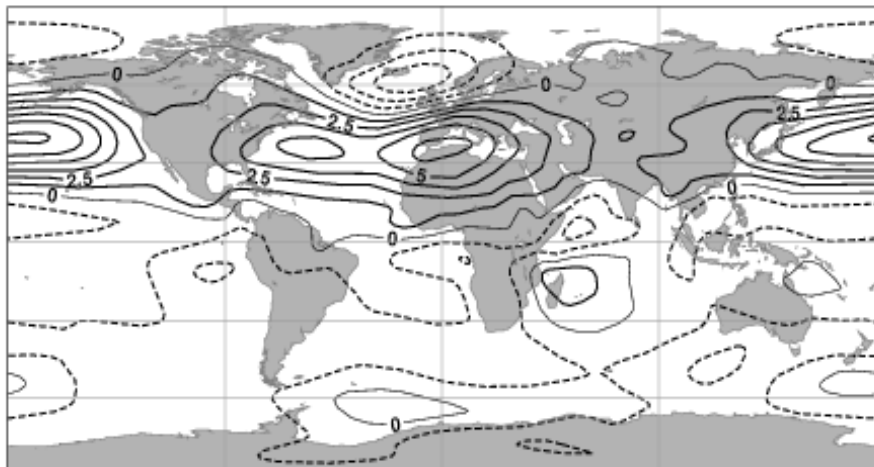

**BIAS Sys3**

Streamfunction 850hPa 36R1-er40 (12-2 1963-2006)

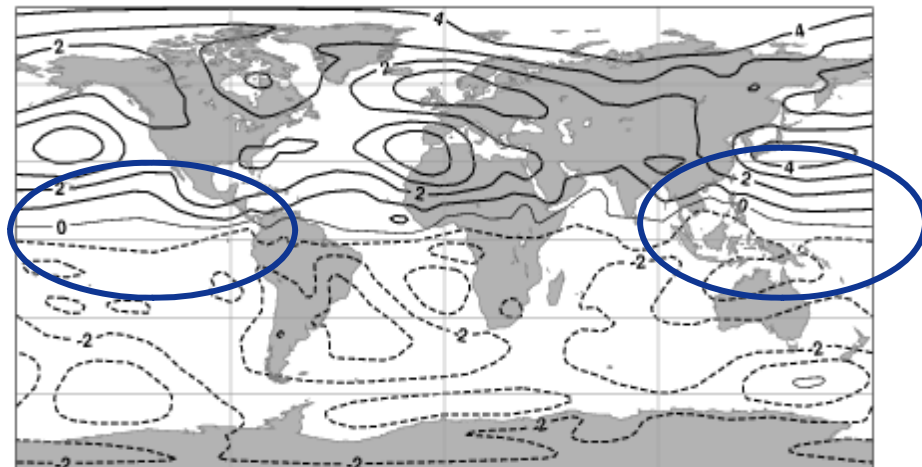

**BIAS 36r1**

# Hindcasts with IFS 36r1: SST bias (1)

Start: 1 Nov.

1989/2008

Verify: Dec-Feb

System 3

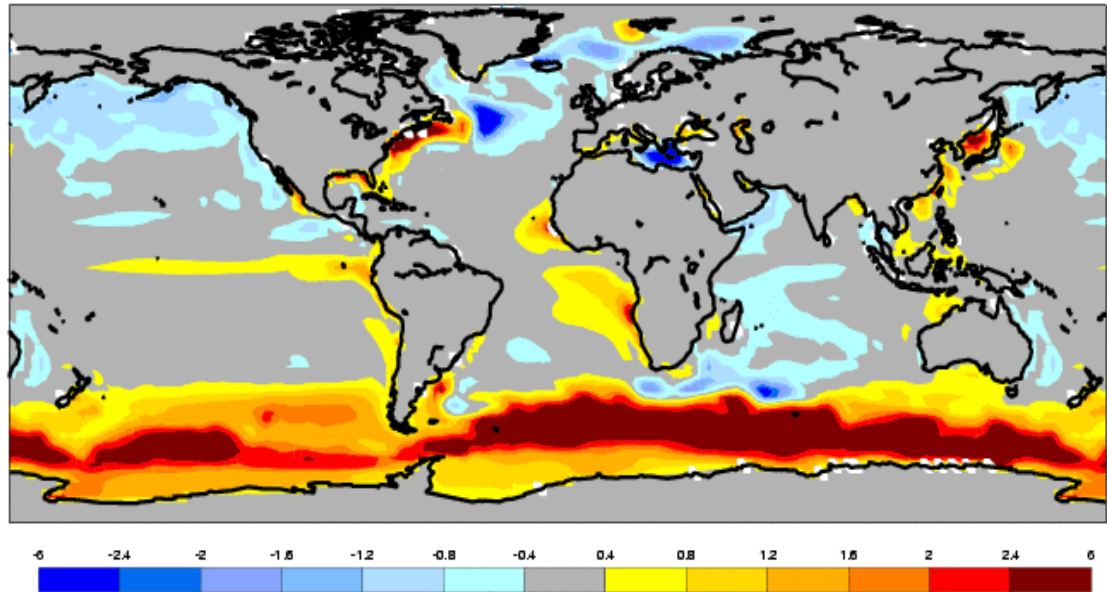

IFS 36r1  
T159/L91  
+ NEMO

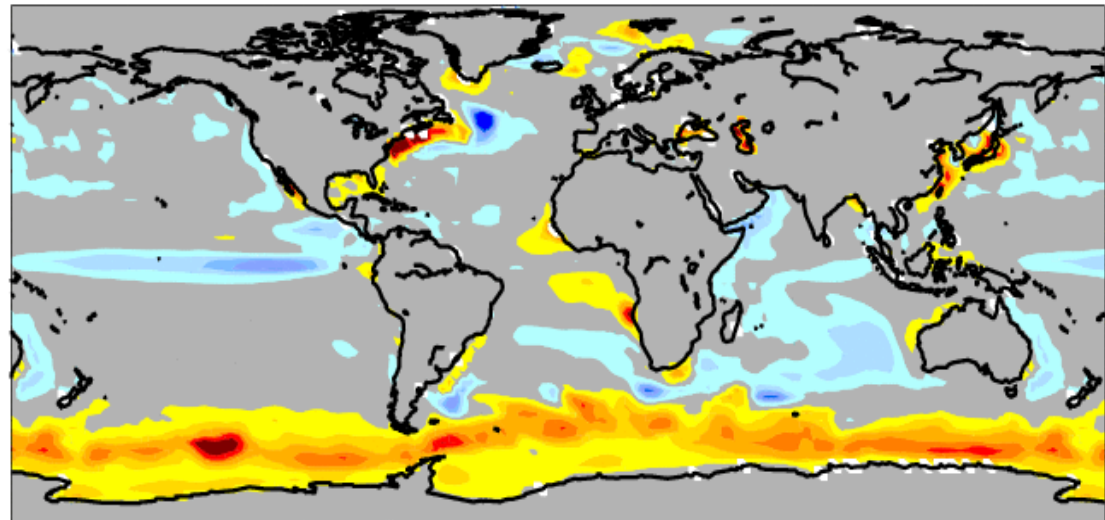

## Future implementations:

- **The seasonal forecasting group is testing a new seasonal forecast system: System 4**
- **An ocean (re-)analysis system using a completely new ocean model and data assimilation system has been set up.**
- **Work to define the final configuration is in progress.**
- **Operational implementation is expected by late 2010 or early 2011.**

# Hindcasts with IFS 36r1: Ens-mean ACC,

$T_{2m}$

Start: 1 Nov.

1989/2008

Verify: Dec-Feb

System 3

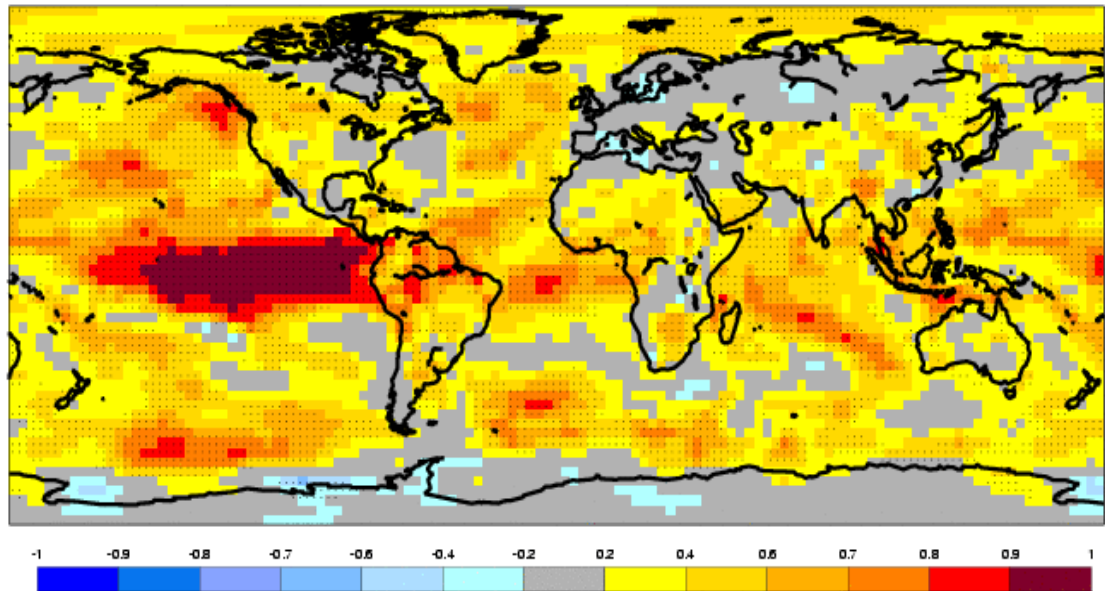

IFS 36r1 + NEMO

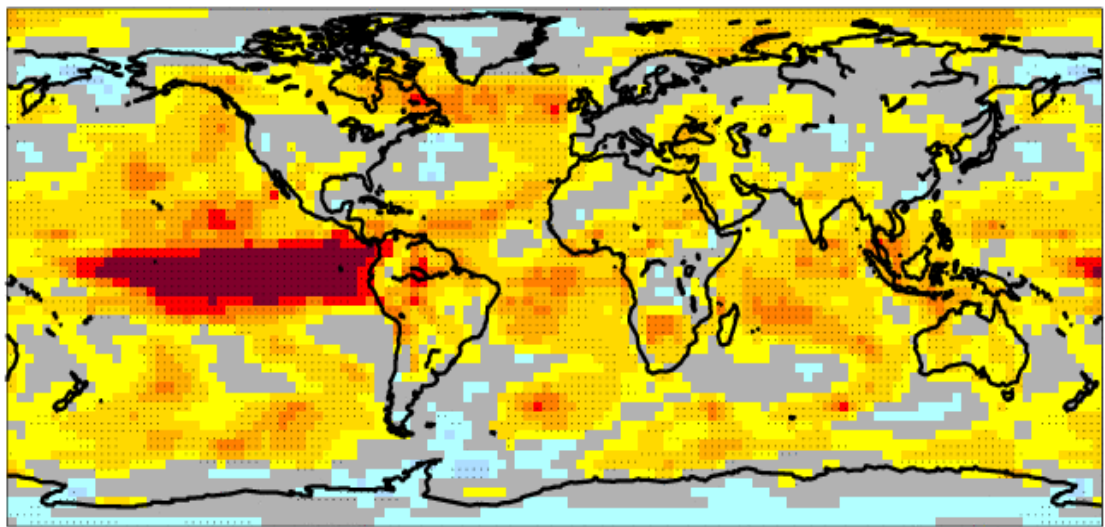

# Ocean Re-Analysis with NEMO at ECMWF

- Using NEMO/NEMOVAR
- Model configuration: ORCA1, smooth coastlines, closed Caspian Sea.
- Forced by ERA40 (until 1989) + ERA Interim (after 1989)
- Assimilates Temperature/Salinity from EN3
- Strong relaxation to SST (OI\_v2)
- Online bias correction scheme
- Preliminary ocean re-analysis 1957-2009
  - This used the EN3\_v2a dataset, where the XBT were not corrected
- First ensemble reanalysis 1957-2009
  - 5 ensemble members (perturbations to wind, initial conditions, observation coverage)
  - Corrected XBT

# Work to do and outstanding issues

## **NEMOVAR**

- **Inclusion of altimeter data**
- **Implementation of real-time suite**

## **Coupled model**

- **Further tests at higher horizontal resolution (T255)**
- **Bias in tropical winds:**
  - **Wait for a “better” IFS cycle (how better?)**
  - **Test flux correction for wind stress/heat fluxes (as a diagnostic tool; an option for Sys-4 ?)**